

# MHA10/13

## HIGH-LEVEL ELECTRIC ORDER PICKER

**MiMA**<sup>®</sup>  
Min Space, Max Performance

BANYITONG SCIENCE & TECHNOLOGY DEVELOPING CO.,LTD  
Tel: +86 551 6219 3112  
E-mail: sales@mimachina.com  
Website: www.mimaforklift.com  
Add: Crossing of Daihe Road and Cailun Road, Hefei, China



# MiMA High-Level Vertical Order Picker



**MHA13**

High-Level Vertical Order Picker

**MHA**

High-Level Vertical Order Picker



## Model: MHA10

Rated capacity: 1000kgs  
 Maximum lift height: 6000mm  
 Maximum picking height: 7600mm  
 Drive type: Man Up standing picking



## Model: MHA13

Rated capacity: 1360kgs  
 Maximum lift height: 9500mm  
 Maximum picking height: 11100mm  
 Drive type: Man Up standing picking

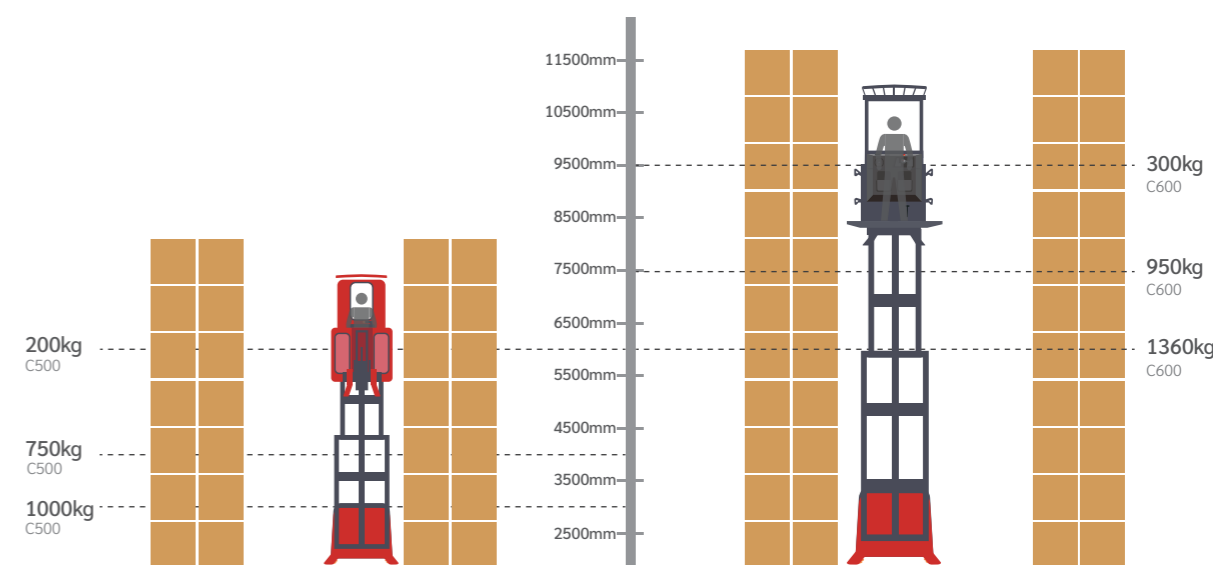

MHA

MHA

Note: The related load should deduct 360 kg when the auxiliary lift is optioned.

## Easy to operate Flexible and fast

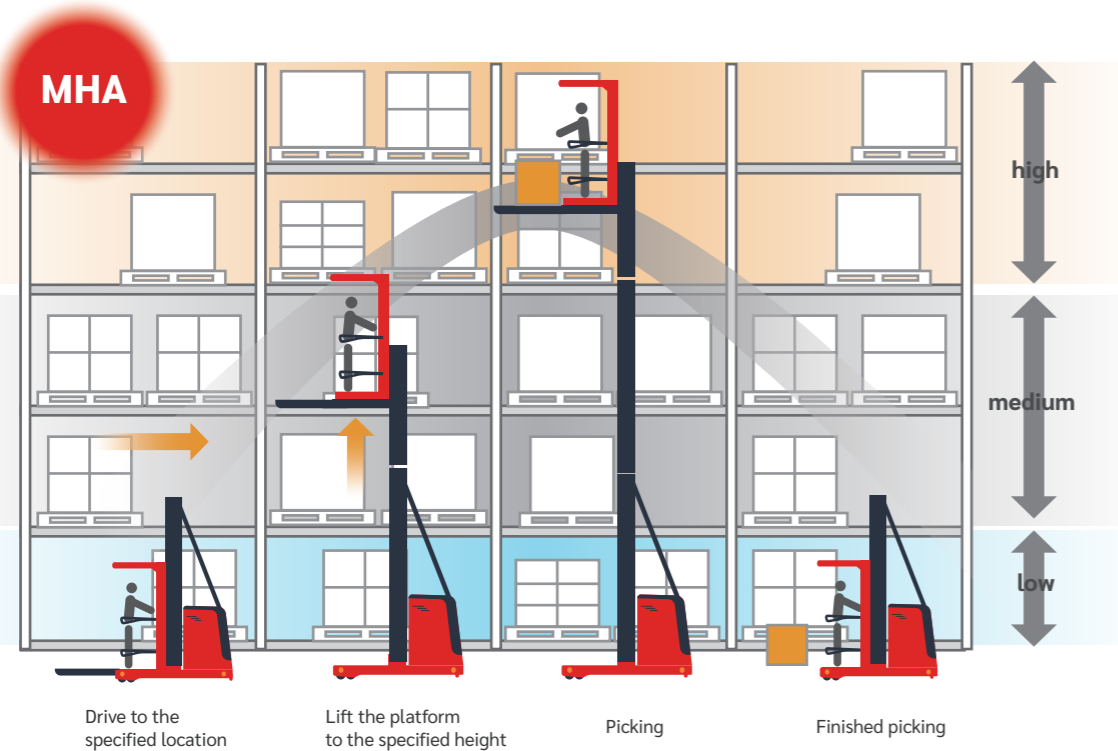
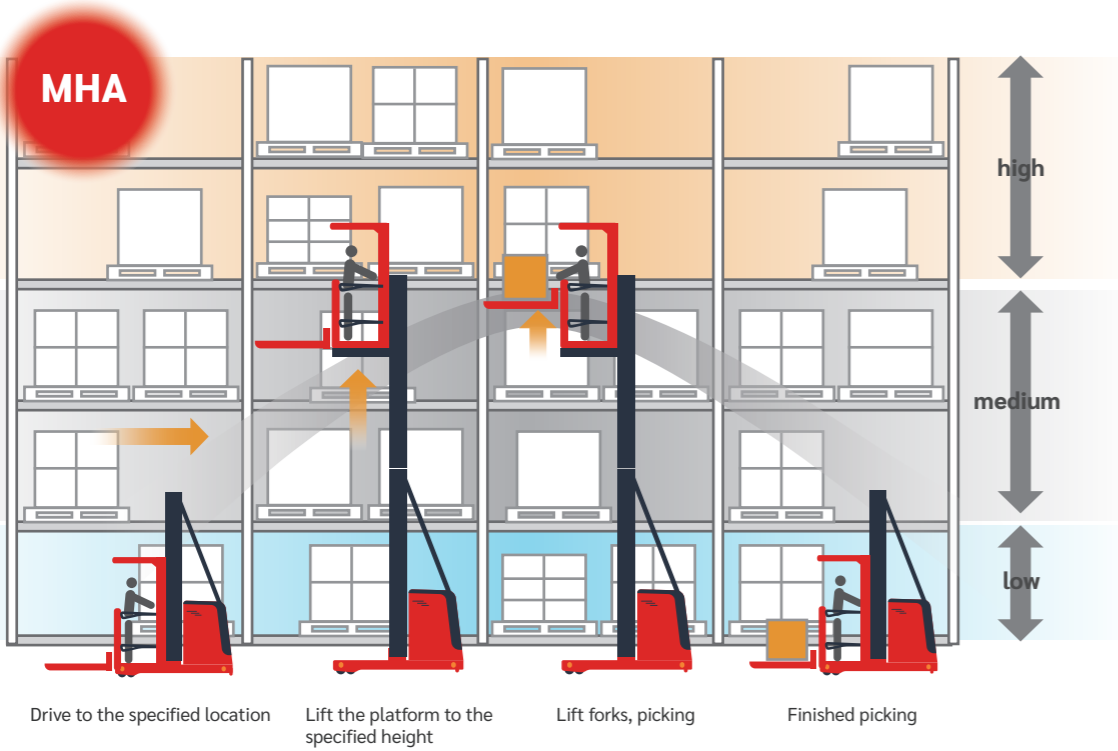

## Working at heights Safety guaranteed



### Smooth

Imported core components, offering superior performance. Proportional lifting system, smooth start and stop.



### Stable

Ergonomic design and cushioned floor provides enhanced stability and comfort over long shifts

### Fold-up monitored side gates

Only when the side gates are in the monitored state and the foot switch is touched can the vehicle be lifted and driven at a high level, provides safe and easy picking.

### Auxiliary lift

Fork can be lifted to a suitable height according to the needs of the operator, more humane, improve work efficiency. Auxiliary lift is optional for MHB series.

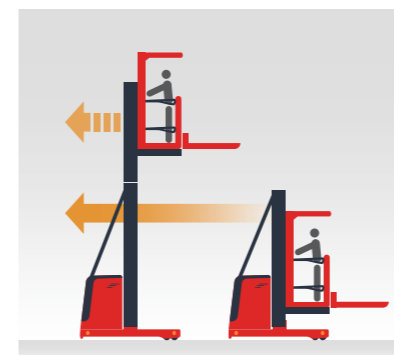

Automatic speed control at high position

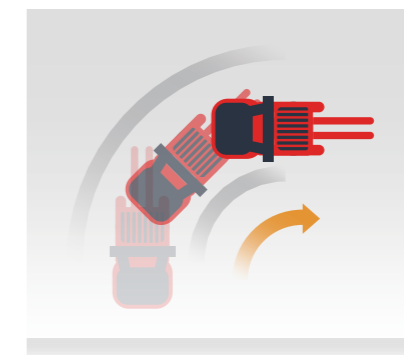

Curve speed control



Lifting electric limit

## Professional Electric Order Picker MHA

In order to improve the efficiency and safety of warehouse picking work, MiMA designed the electric order picker MHA for mid-high level picking conditions in warehouses. The overall width of MHA is as narrow as 1,150mm, which can be used for picking in very narrow aisle.



# 7600

Max. picking height



# 6000

Max. lifting height of the platform



# 1150

Overall width

## High Configuration Superior Performance

Key components are all adopt imported brands, such as electric control assembly, pump station, instrument, control handle, thumb switch, cable, etc. The steer drive wheel angle is clearly displayed, more easier for the operator to control the vehicle. The battery upper cover and the drive motor cover can be easy to open, making battery maintenance and whole vehicle maintenance more convenient and labor-saving.



Optimal visibility



console



side pull battery



AC motor

## Customized

Standard



Open-style



## Professional High-Level Electric Order Picker MHA13

MiMA new designed high level electric order picker MHA13. 48 - Volt electrical system, full AC motor technology, up to 1,360 Kg capacity (abbr. 3000 lbs ). Lift height up to 9,500 mm, reaches racking up to 11,100 mm. Key components are all adopt imported brands. Offering superior performance. Equipped with automatic speed control at high position, curve speed control and other functions, making the vehicle more stable and safer.



# 11100

Max. picking height



# 9500

Max. lifting height of the platform



# 1524

Overall width

## High Configuration Superior Performance

MHB is an upgraded version of MHA, the picking height reaches up to 11,100mm. Imported key components, such as such as Curtis controller, Shimadzu gear pump, Hydra Force Cartridge valve group, Gessmann control handle, Tokai hydraulic hoses, and SICK wire draw encoder, ensuring high-level operations of the vehicle. Top travel and hydraulic lift speeds take order picking efficiency and performance to the next level.

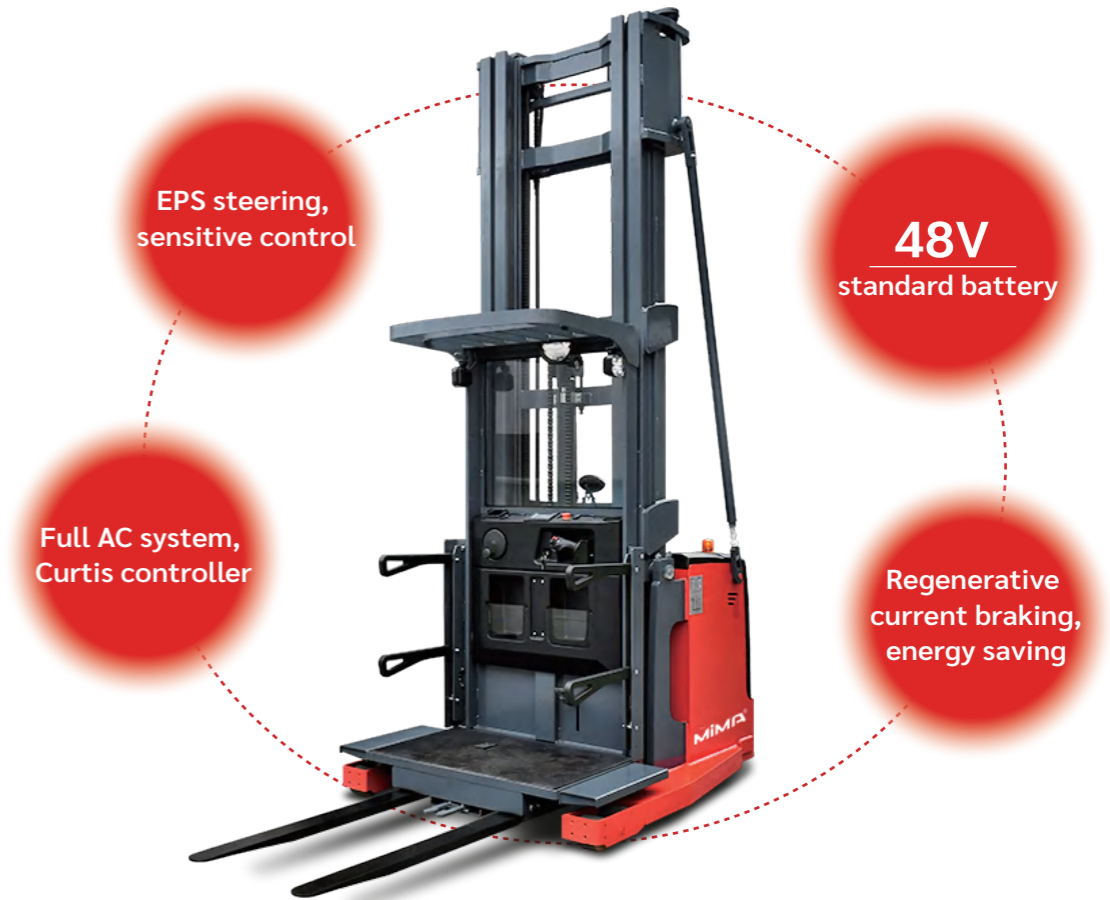

Driving speed(km/h)

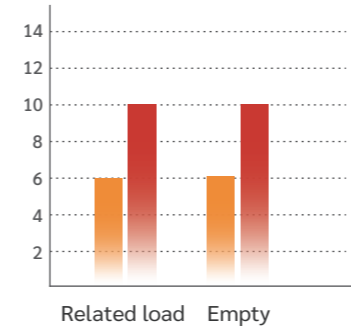

Lifting speed(km/h)



Lowering speed(km/h)

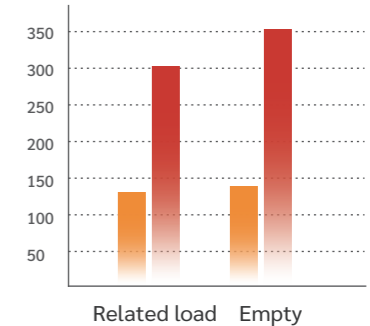

MHA  
MHA13

# Customized functions and optional configuration



● **Magnetic guidance/wire guidance(Optional)** No need to install ground guide rail, avoid ground construction and reduce warehouse construction costs.

Magnetic navigation/ electric navigation

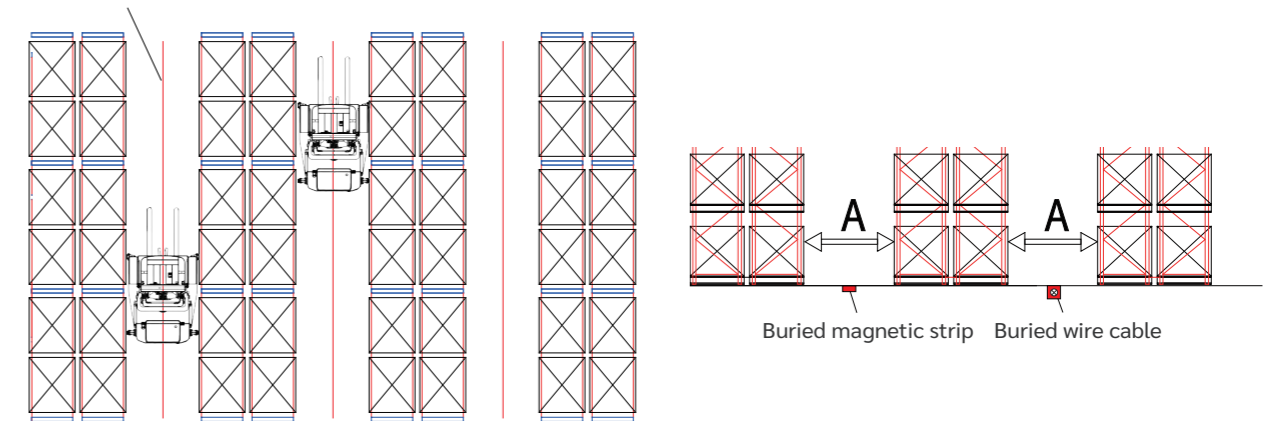

● Other options	Overload warning (load display, not for metering).	Fork option lengths available
	Guide rollers	Double side consoles, fork direction/mast direction
	Customized fork length	Protective mast guard wire mesh
	LED working light	Fan

Note: All the above configurations may involve optional items. Please consult our sales manager before purchasing.

Characters				
1.1	Manufacturer	MHA1030	MHA1060S	
1.2	Model	Battery	Battery	
1.3	Power Type	Stand on	Stand on	
1.4	Operation Type	Q(kg)	1000	1000
1.5	Load Center C(mm)	C(mm)	500	500
1.6	Front Overhang	x(mm)	148	160
1.7	Wheelbase y(mm)	y(mm)	1410	1410
Weight				
2.1	Service Weight(incl.battery)	kg	2490	2830
2.2	Weight distribution when loaded, drive side/load side	kg	940/2550	1130/2700
2.3	Weight distribution when unloaded, drive side/load side	kg	1410/1080	1610/1220
Wheel				
3.1	Wheel Types	PU	PU	
3.2	Load Wheel	mm	φ 150×90	φ 150×90
3.3	Drive wheel	mm	φ 254×100	φ 254×100
3.4	Number of wheels,front/rear(x=drive wheel)		4/1X	4/1X
3.5	Wheel tread,load side	b11(mm)	1008	1008
Size				
4.1	Mast closed height	h1(mm)	2300	2815
4.2	Lift height	h3(mm)	2760	5760
4.3	Max lift height of fork	h25(mm)	3530	6530
4.4	Mast extended height	h4(mm)	5010	7955
4.5	Overhead guard height	h6(mm)	2270	2270
4.6	Platform min.ground clearance	h7(mm)	260	260
4.7	Auxiliary lift height	h9(mm)	700	700
4.8	Platform max.ground clearance	h12(mm)	3000	6000
4.9	Picking height (h12+1600mm)	h28(mm)	4600	7600
4.10	Fork face min.ground clearance	h13(mm)	70	70
4.11	Overall length	l1(mm)	2825	2835
4.12	Length to fork face	l2(mm)	1755	1765
4.13	Overall width	b1/b2(mm)	1150	1150
4.14	Fork size	l/e/s(mm)	1070/100/40	1070/100/40
4.15	Fork outside width	b5(mm)	700	700
4.16	Guide wheel width	b6(mm)	1336	1336
4.17	Mast ground clearance	m1(mm)	50	50
4.18	Body ground clearance	m2(mm)	50	50
4.19	"Aisle width for pallet 1000*1200 1200 Cross fork direction"	Ast(mm)	3120	3130
4.20	"Aisle width for pallet 800*1200 1200 Extended fork direction"	Ast(mm)	3230	3245
4.21	Turning radius	Wa(mm)	1625	1625
Function				
5.1	Driving speed(load/unload)	km/h	6/6.3	6/6.3
5.2	Lifting speed(load/unload)	mm/s	115/140	115/140
5.3	Lowering speed(load/unload)	mm/s	135/140	135/140
5.4	Brake type		Electromagnetic type	Electromagnetic type
Drive				
6.1	Driving motor(S2-60min)	kw	2.5	2.5
6.2	Lifting motor(S3-15%)	kw	3	3
6.3	Battery voltage/capacity	V/Ah	24/400	24/400
6.4	Battery weight	kg	350	350
Others				
7.1	Driving motor type		AC	AC
7.2	Driver ear noise (EN12053 Standard)	dB(A)	70	70
7.3	Steering system		Electric Power Steering	Electric Power Steering

### Three-view drawing

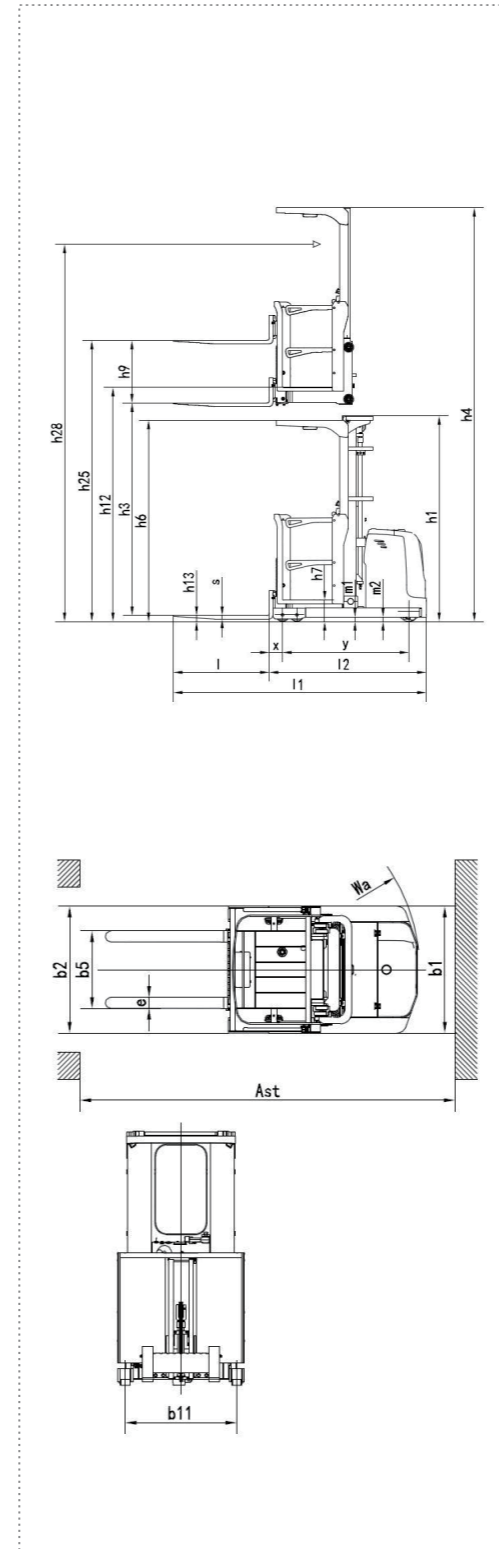

### Mast Specification

Duplex Mast					
Model	MHA	10-30	10-35	10-40	10-45
Lift height	h3	2760	3260	3760	4260
Total lift height	h24(h3+h9)	3460	3960	4460	4960
Fork lift height	h25(h3+h9+h13)	3530	4030	4530	5030
Auxiliary lift height	h9	700	700	700	700
Platform lift height	h12(h3+h7)	3000	3500	4000	4500
Picking height	h28(h12+1600)	4600	5100	5600	6100
Mast closed height	h1	2300	2550	2850	3100
Max mast extended height	h4	5010	5510	6060	6610

Triplex Mast						
Model	MHA	10-40S	10-45S	10-50S	10-55S	10-60S
Lift height	h3	3760	4260	4760	5260	5760
Total lift height	h24(h3+h9)	4460	4960	5460	5960	6460
Fork lift height	h25(h3+h9+h13)	4530	5030	5530	6030	6530
Auxiliary lift height	h9	700	700	700	700	700
Platform lift height	h12(h3+h7)	4000	4500	5000	5500	6000
Picking height	h28(h12+1600)	5600	6100	6600	7100	7600
Mast closed height	h1	2149	2316	2482	2649	2815
Max mast extended height	h4	5955	6455	6955	7455	7955

### Capacity chart

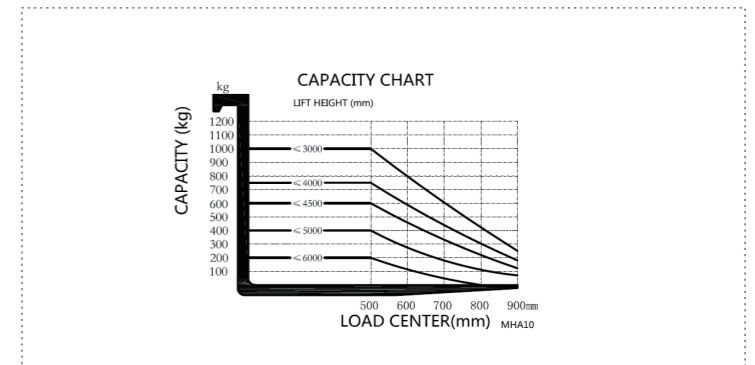

Characters			
1.1	Model	MHA1395SQ	
1.2	Power Type	Battery	
1.3	Operation Type	Stand on	
1.4	Rated Capacity	Q(kg)	1360
1.5	Load Center	C(mm)	600
1.6	Front Overhang	x(mm)	213
1.7	Wheelbase	y(mm)	1495
Weight			
2.1	Service Weight(incl.battery)	kg	4800
Wheel			
3.1	Wheel Types		PU
3.2	Load Wheel	mm	φ 140×100
3.3	Drive wheel	mm	φ 343×120
3.4	Number of wheels,front/rear(x=drive wheel)		4/1X
3.5	Wheel tread,load side	b11(mm)	1353
Size			
4.1	Mast closed height	h1(mm)	4044
4.2	Lift height	h3(mm)	9280
4.3	Max lift height of fork	h25(mm)	9350
4.4	Mast extended height	h4(mm)	11711
4.5	Overhead guard height	h6(mm)	2251
4.6	Platform min.ground clearance	h7(mm)	220
4.7	Platform max.ground clearance	h12(mm)	9500
4.8	Picking height (h12+1600mm)	h28(mm)	11100
4.9	Fork face min.ground clearance	h13(mm)	70
4.10	Overall length	l1(mm)	3160
4.11	Length to fork face	l2(mm)	1928
4.12	Overall width	b1/b2(mm)	1190/1524
4.13	Fork size	l/e/s(mm)	1220/100/40
4.14	Fork outside width	b5(mm)	700
4.15	Guide wheel width	b6(mm)	1604
4.16	Mast ground clearance	m1(mm)	50
4.17	Body ground clearance	m2(mm)	50
4.18	Turning radius	Wa(mm)	1780
Function			
5.1	Driving speed(load/unload)	km/h	10/10
5.2	Lifting speed(load/unload)	mm/s	260/300
5.3	Lowering speed(load/unload)	mm/s	300/350
5.4	Brake type		Electromagnetic type
Drive			
6.1	Driving motor(S2-60min)	kw	6.5
6.2	Lifting motor(S3-15%)	kw	12.5
6.3	Steering motor	kw	0.6
6.4	Battery voltage/capacity	V/Ah	48/450
6.5	Battery weight	kg	767
Others			
7.1	Driving motor type		AC
7.2	Driver ear noise (EN12053 Standard)	dB(A)	75
7.3	Steering system		Electric power steering

The standard model data would vary according to the configuration

### Three-view drawing

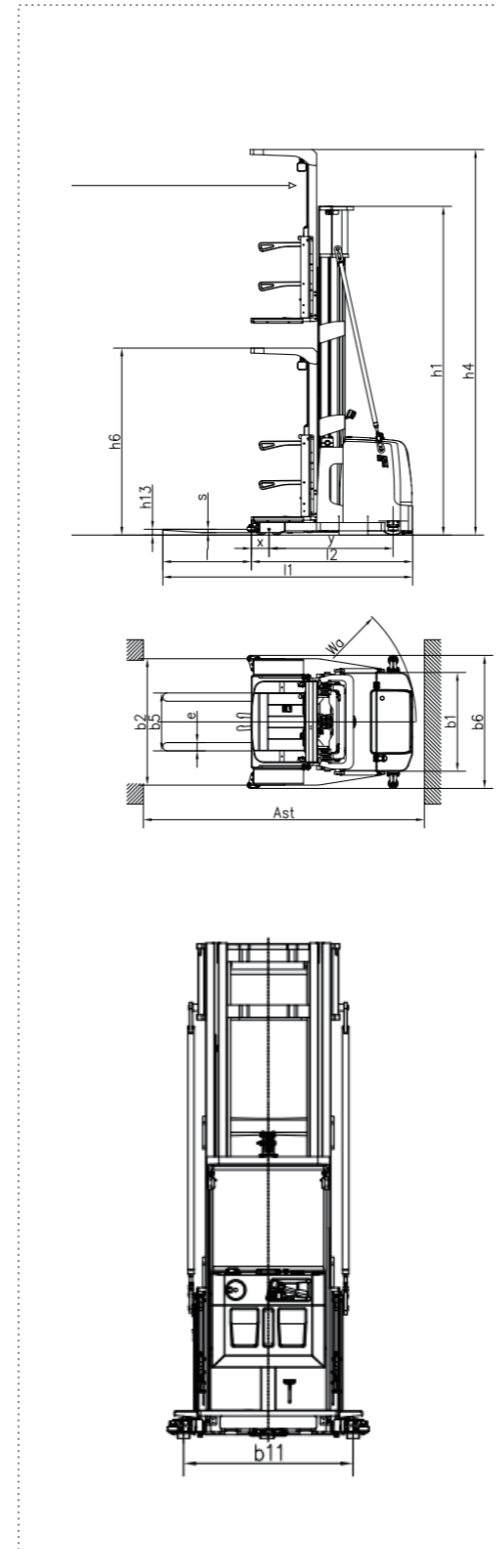

### Mast Specification

Duplex Mast								
Model	MHA13	13-30	13-37	13-40	13-45	13-50	13-55	13-60
Lift height	h3	2780	3480	3780	4280	4780	5280	5780
Platform lift height	h12(h3+h7)	3000	3700	4000	4500	5000	5500	6000
Picking height	h28(h12+1600)	4600	5300	5600	6100	6600	7100	7600
Mast closed height	h1	2461	2728	2928	3128	3377	3711	3878
Max mast extended height	h4	5035	5735	6035	6535	7035	7535	8035

Triplex Mast								
Model	MHA13	13-60	13-65	13-70	13-75	13-80	13-85	13-90
Lift height	h3	5780	6280	6780	7280	7780	8280	8780
Platform lift height	h12(h3+h7)	6000	6500	7000	7500	8000	8500	9000
Picking height	h28(h12+1600)	7600	8100	8600	9100	9600	10100	10600
Mast closed height	h1	2928	3095	3211	3377	3544	3711	3878
Max mast extended height	h4	8035	8535	9035	9535	10035	10535	11035

### Capacity chart

